

Job: _____

Item: _____

Quantity: _____

Lug Dollies - 6000 Series

- Ideal for bulk food transporting.
- Accept the standard lugs (16"W x 8½"H x 25"L).

MATERIAL:

- Framework is constructed out of 1 ¼" x 1 ¼" x .070" wall tubing.
- Angle runners are 1 ¼" x 1 ¼" x .100" wall angle.

CASTERS:

- Equipped with four 5" stem type swivel casters.

GUARANTEE:

- Lifetime Guarantee against rust and corrosion.
- One-Year Guarantee against material defects and workmanship.

NSF Certified.

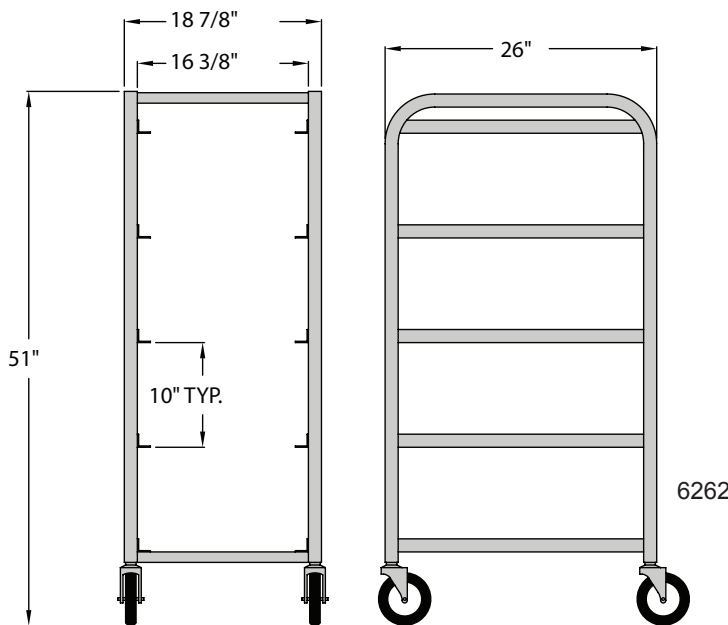

Model No.	Lug Cap.	Size W-H-D	Ship Wt.
6265	1	15¾" x 19" x 26"	11.5#
6266	2	15¾" x 33" x 28¼"	16#
97205*	3	18⅞" x 42" x 26"	23#
6262	4	18⅞" x 51" x 26"	31#5
97253*	5	18⅞" x 61" x 26"	31#
6263	6	18⅞" x 71" x 26"	32#

Four 5" swivel type stem casters(#C480). No brakes.
 * Not NSF Approved.

OPTIONS:

Caster Locks (2) - Add "CL" suffix to the model number.

Distributed by:

This information is for general sales and engineering use only. New Age Industrial reserves the right to modify or make changes at any time without notice to materials and specifications.

