



# TRUE FOOD SERVICE EQUIPMENT, INC.

2001 East Terra Lane • O'Fallon, Missouri 63366-4434 • (636)240-2400  
Fax (636)272-2408 • Toll Free (800)325-6152 • Intl Fax# (001)636-272-7546  
Parts Dept. (800)424-TRUE • Parts Dept. Fax# (636)272-9471 • www.truemfg.com

Project Name: \_\_\_\_\_

Location: \_\_\_\_\_

Item #: \_\_\_\_\_ Qty: \_\_\_\_\_

Model #: \_\_\_\_\_

A/A #

SIS #

Model:  
**T-23-HC**

## T-Series:

*Reach-In Solid Swing Door Refrigerator with Hydrocarbon Refrigerant*



## T-23-HC

- ▶ True's solid door reach-in's are designed with enduring quality that protects your long term investment.
  - ▶ Designed using the highest quality materials and components to provide the user with colder product temperatures, lower utility costs, exceptional food safety and the best value in today's food service marketplace.
  - ▶ Factory engineered, self-contained, capillary tube system using environmentally friendly R290 hydro carbon refrigerant that has zero (0) ozone depletion potential (ODP), & three (3) global warming potential (GWP).
  - ▶ Oversized, factory balanced, refrigeration system holds 33°F to 38°F (.5°C to 3.3°C) for the best in food preservation.
  - ▶ Stainless steel solid door and front. The finest stainless available with higher tensile strength for fewer dents and scratches.
  - ▶ Adjustable, heavy duty PVC coated shelves.
  - ▶ Positive seal self-closing door. Lifetime guaranteed door hinges and torsion type closure system.
- Bottom mounted units feature**
- ▶ "No stoop" lower shelf.
  - ▶ Storage on top of cabinet.
  - ▶ Compressor performs in coolest, most grease free area of kitchen.
  - ▶ Easily accessible condenser coil for cleaning.

## ROUGH-IN DATA

Specifications subject to change without notice.  
Chart dimensions rounded up to the nearest 1/8" (millimeters rounded up to next whole number).

Model	Doors	Shelves	Cabinet Dimensions (inches) (mm)			HP	Voltage	Amps	NEMA Config.	Cord Length (total ft.) (total m)	Crated Weight (lbs.) (kg)
			L	D	H*						
T-23-HC	1	3	27 686	29½ 750	78¾ 1991	½ ¾	115/60/1 230-240/50/1	3.0 2.4	5-15P ▲	9 2.74	280 127

\* Height does not include 5" (127 mm) for castors or 6" (153 mm) for optional legs.

▲ Plug type varies by country.



APPROVALS:

AVAILABLE AT:

Model:  
**T-23-HC**

**T-Series:**  
*Reach-In Solid Swing Door Refrigerator with Hydrocarbon Refrigerant*



**STANDARD FEATURES**

**DESIGN**

- True's commitment to using the highest quality materials and optimized refrigeration systems provides the user with colder product temperatures, lower utility costs, exceptional food safety and the best value in today's food service marketplace.

**REFRIGERATION SYSTEM**

- Factory engineered, self-contained, capillary tube system using environmentally friendly R290 hydro carbon refrigerant that has zero (0) ozone depletion potential (ODP), & three (3) global warming potential (GWP).
- Evaporator coil balanced with higher horsepower compressor and large condenser; maintains 33°F to 38°F (0.5°C to 3.3°C) for the best in food preservation.
- Sealed evaporator fan motors and larger fan blades give True reach-in's a more efficient airflow design. This unique design ensures faster temperature recovery and shorter run times in the busiest of food service environments.
- Bottom mounted condensing unit positioned for easy maintenance. Compressor runs in coolest and most grease free area of the kitchen. Allows for storage area on top of unit.

**CABINET CONSTRUCTION**

- Exterior - Stainless steel front. Anodized quality aluminum ends, back and top.
- Interior - attractive, NSF approved, clear coated aluminum liner. Stainless steel floor with coved corners.

- Insulation - entire cabinet structure and solid door are foamed-in-place using Ecomate. A high density, polyurethane insulation that has zero ozone depletion potential (ODP) and zero global warming potential (GWP).
- Welded, heavy duty steel frame rail, black powder coated for corrosion protection.
- Frame rail fitted with 4" (102 mm) diameter stem castors - locks provided on front set.

**DOOR**

- Stainless steel exterior with white aluminum liner to match cabinet interior. Door extends full width of cabinet shell. Door locks standard.
- Lifetime guaranteed recessed door handle. Door fitted with 12" (305 mm) long recessed handle that is foamed-in-place with a sheet metal interlock to ensure permanent attachment.
- Positive seal self-closing door. Lifetime guaranteed door hinges and torsion type closure system.
- Magnetic door gasket of one piece construction, removable without tools for ease of cleaning.

**SHELVING**

- Three (3) adjustable, heavy duty PVC coated wire shelves 22 7/8" L x 23 1/4" D (582 mm x 591 mm). Four (4) chrome plated shelf clips included per shelf.
- Shelf support pilasters made of same material as cabinet interior; shelves are adjustable on 1/2" (13 mm) increments.

**LIGHTING**

- Interior lighting - safety shielded. Lights activated by rocker switch mounted above door.

**MODEL FEATURES**

- Exterior temperature display.
- Evaporator is epoxy coated to eliminate the potential of corrosion.

**ELECTRICAL**

- Unit completely pre-wired at factory and ready for final connection to a 115/60/1 phase, 15 amp dedicated outlet. Cord and plug set included.



115/60/1  
NEMA-5-15R

**OPTIONAL FEATURES/ACCESSORIES**

Upcharge and lead times may apply.

- 230 - 240V / 50 Hz.
- 6" (153 mm) standard legs.
- 6" (153 mm) seismic/flanged legs.
- Alternate door hinging (factory installed).
- Additional shelves.
- Half door bun tray racks. Each holds up to eleven 18"L x 26"D (458 mm x 661 mm) sheet pans (sold separately).
- Full door bun tray rack. Holds up to twenty-two 18"L x 26"D (458 mm x 661 mm) sheet pans (sold separately).

**PLAN VIEW**

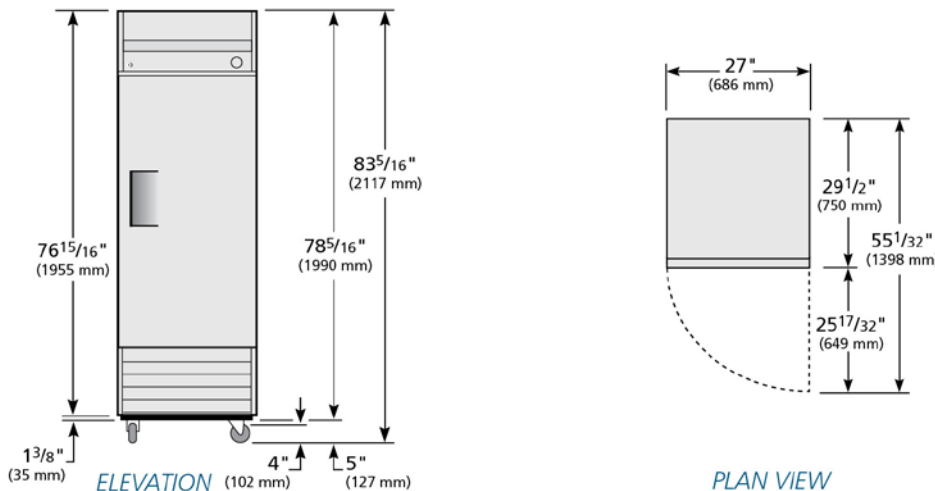

**WARRANTY\***  
 Three year warranty on all parts and labor and an additional 2 year warranty on compressor. (U.S.A. only)

METRIC DIMENSIONS ROUNDED UP TO THE NEAREST WHOLE MILLIMETER  
 SPECIFICATIONS SUBJECT TO CHANGE WITHOUT NOTICE

KCL	Model	Elevation	Right	Plan	3D	Back
	T-23-HC	TFEY53E	TFEY03S	TFEY03P	TFEY633	

**TRUE FOOD SERVICE EQUIPMENT**

\*RESIDENTIAL APPLICATIONS: TRUE assumes no liability for parts or labor coverage for component failure or other damages resulting from installation in non-commercial or residential applications. Units with R290 refrigerant are not approved by UL/EPA for use in residential applications.